

# Integration Solar Street Light

## Product Specification

40W-100W



### Product Picture:



### Features:

- \* Die casting casing lamp body
- \* No ac power cables, no electricity charges
- \* LED lumen 160lm/w
- \* IP65 rating

### Applications:

- \* Plazas, courtyards
- \* Rural road lighting
- \* Gardens, parks
- \* Sporting venues

### Product Parameter:

Model	0310B40-03	0310C60-03	0310D100-03
LED Type	200Pcs 5730LED	200Pcs 5730LED	400Pcs 5730LED
Battery Type	LiFePO4 12.8V 18AH	LiFePO4 12.8V 24AH	LiFePO4 12.8V 42AH
Solar Panel Type	Mono-Crystalline 29W16V	Mono-Crystalline 36W16V	Mono-Crystalline 48W16V
LED Lumen	160lm/w		
Color Temperature	3000K-6500K		
LED Lifespan	50000H		
Sensing Method	Time Control/Motion Detection		
Operating Temperature	-20°C~60°C		
Storage Temperature	-30°C~70°C		
IP Rating	IP65		
Gross weight/Carton	8.5Kg	9.3Kg	14Kg
Product Size	740*340*82mm	860*340*82mm	980*360*125mm
Package Size	750*350*100mm 1Pcs/Box	880*350*110mm 1Pcs/Box	990*370*160mm 1Pcs/Box

Integration Solar Street Light

NELSON SOLAR

BP 6635 Ouagadougou CNT Ouaga

BURKINA FASO

WWW.NELSONSOLAR.COM



**Lighting Data:**

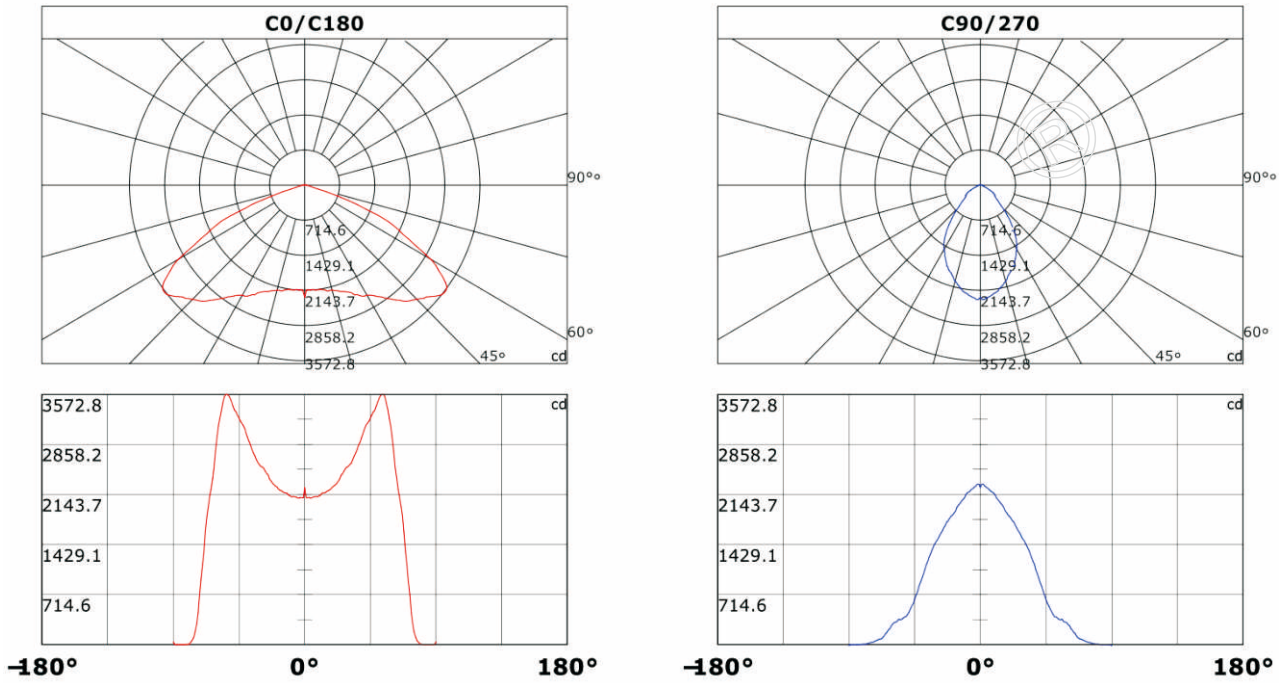

**Installation Dimension:**

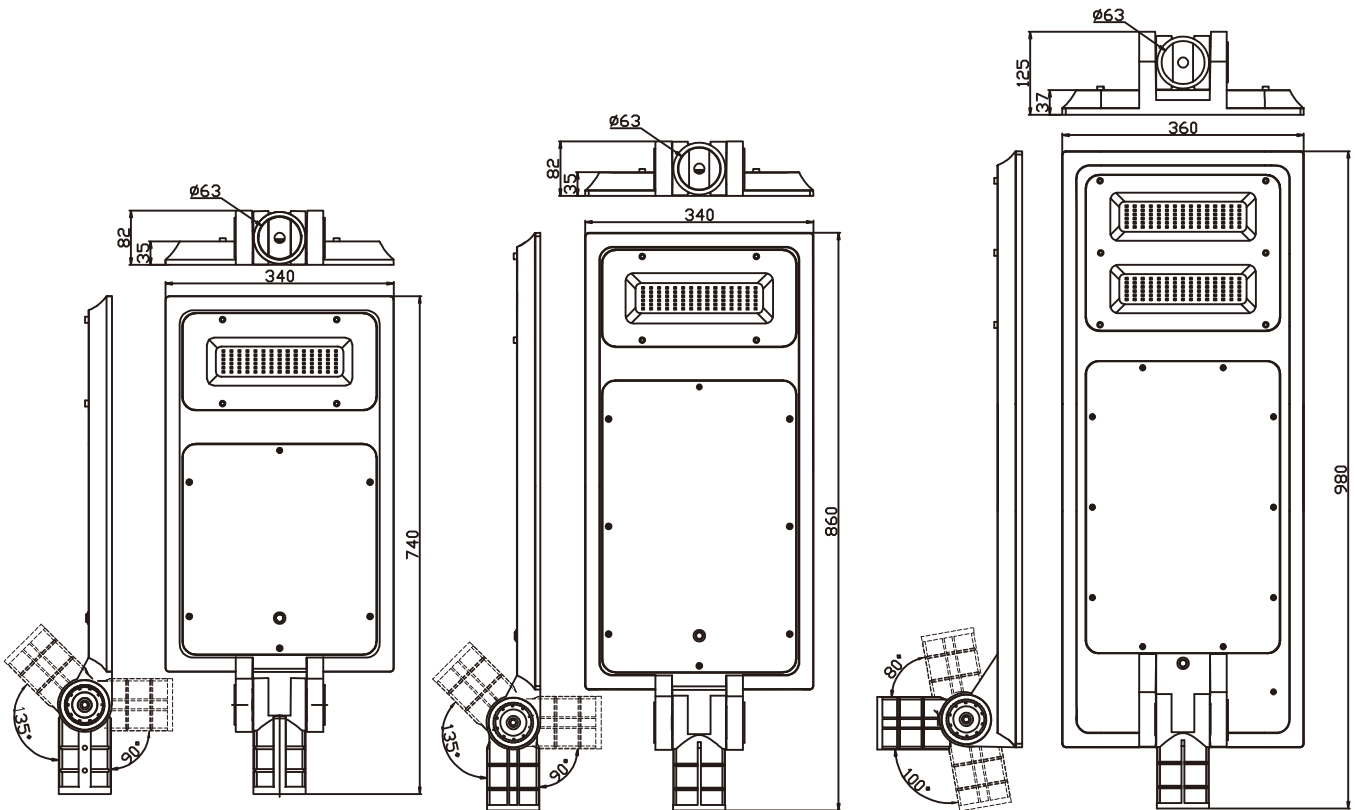

# Solar LED Street Light

## Product Specification

30W-180W-NELSON SOLAR

### Product Picture:



Solar Led Street Light

### Features:

- \* Die casting casing lamp body
- \* No ac power cables, no electricity charges
- \* LED lumen 160lm/w
- \* IP65 rating

### Applications:

- \* Plazas
- \* Factories, schools
- \* Gardens, parks
- \* Sporting venues

### Product Parameter:

Model	0830A30-02	0830B60-02	0830C90-02	0830D120-02	0830E150-02	0830F180-02
LED Type	30PCS 3030LED	50PCS 3030LED	100PCS 3030LED	100PCS 3030LED	150PCS 3030LED	150PCS 3030LED
Battery Type	LiFePO4 12.8V 30AH	LiFePO4 12.8V 36AH	LiFePO4 12.8V 45AH	LiFePO4 12.8V 54AH	LiFePO4 25.6V 45AH	LiFePO4 25.6V 54AH
Solar Panel Type	Polycrystalline 30W 18V	Polycrystalline 60W 18V	Polycrystalline 90W 18V	Polycrystalline 120W 18V	Polycrystalline 150W 36V	Polycrystalline 180W 36V
Color Temperature	3000K-6500K					
LED Lifespan	50000H					
Control Method	Time control					
Operating Temperature	-20°C~ 60°C					
Storage Temperature	-30°C~ 70°C					
Gross Weight/Carton	10.6KG	19KG	30KG	31KG	34KG	35KG
Product Size	510*430*370mm	680*620*330mm	680*620*330mm	680*620*330mm	970*465*270mm	970*465*270mm
Package Size	1Pcs/Box	1Pcs/Box	940*70*690mm 1Pcs/Box	1205*70*690mm 1Pcs/Box	1020*80*1000mm 1Pcs/Box	1170*80*1010mm 1Pcs/Box

NELSON SOLAR

BP 6635 Ouagadougou CNT Ouaga

BURKINA FASO

WWW.NELSONSOLAR.COM



## Lighting Data:

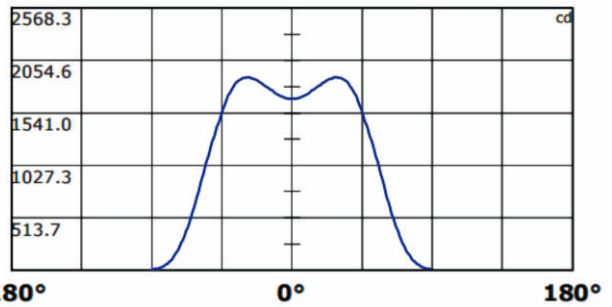
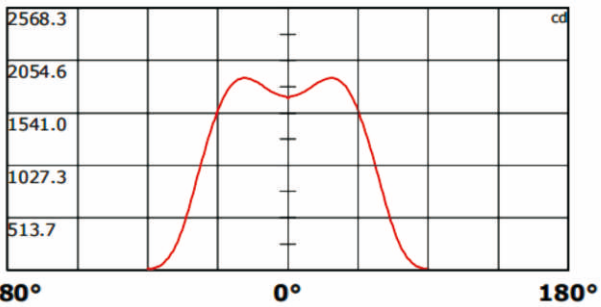
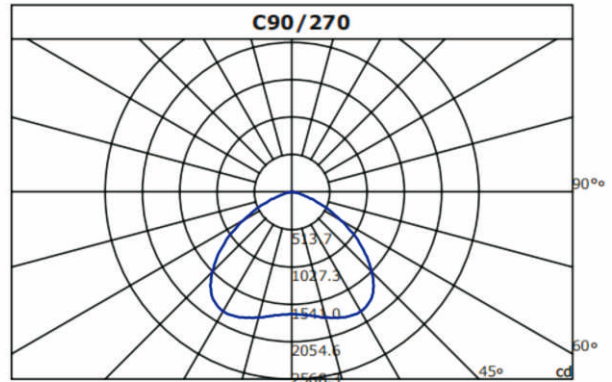
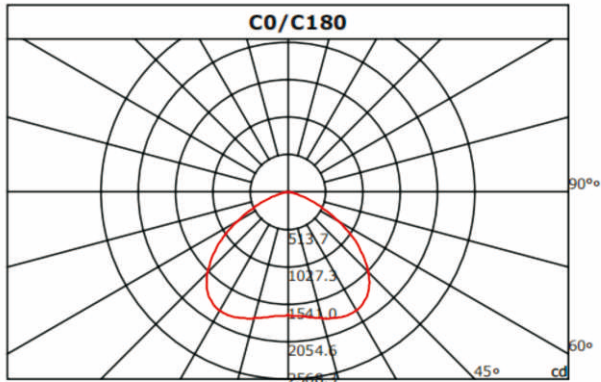

## Installation Dimension:

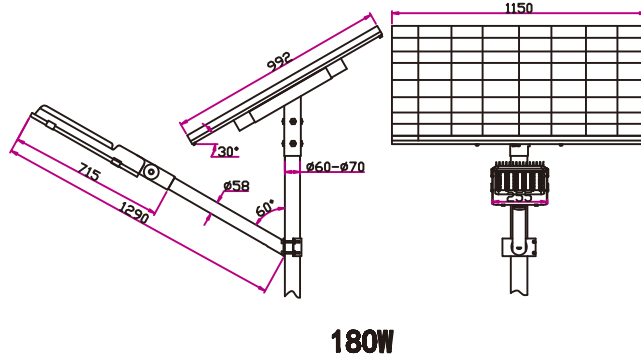
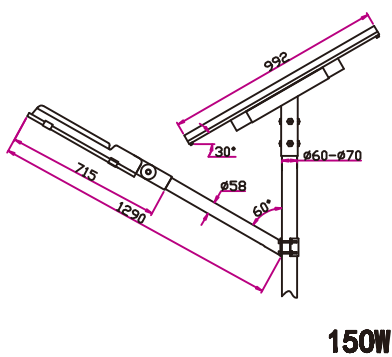
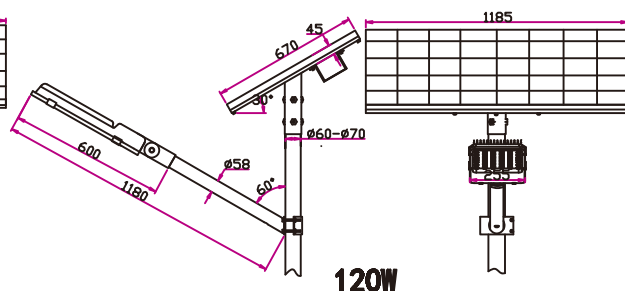
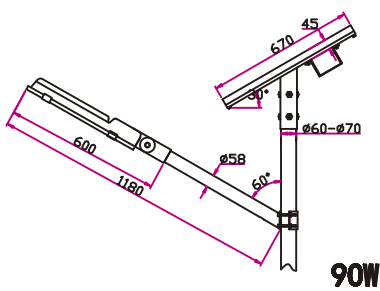
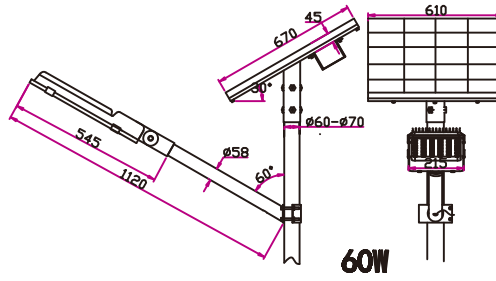
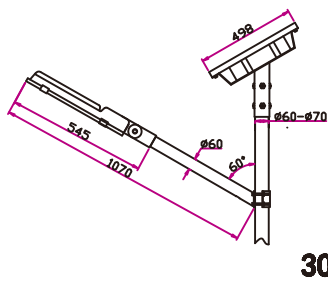

# Integration Solar Street Light

## Product Specification

30-150W



Integration Solar Street Light

### Product Picture:



### Features:

- \* Plastic abs lamp body
- \* No ac power cables, no electricity charges
- \* LED lumen 160lm/w
- \* IP65 rating

### Applications:

- \* Plazas, courtyards
- \* Rural road lighting
- \* Gardens, parks
- \* Sporting venues

### Product Parameter:

Model	0845A30-01	0845B60-01	0845C90-01	0845D120-01	0845E150-01
LED Type	60PCS 5730LED	120PCS 5730LED	180PCS 5730LED	240PCS 5730LED	300PCS 5730LED
Battery Type	LiFePO4 3.2V 12AH	LiFePO4 3.2V 18AH	LiFePO4 3.2V 24AH	LiFePO4 3.2V 30AH	LiFePO4 3.2V 36AH
Solar Panel Type	Polycrystalline 7W 6V	Polycrystalline 9W 6V	Polycrystalline 12W 6V	Polycrystalline 14.5W 6V	Polycrystalline 17.5W 6V
Color Temperature	3000K-6500K				
LED Lifespan	50000H				
Control Method	PIR Detection				
Operating Temperature	-20°C ~ 60°C				
Storage Temperature	-30°C ~ 70°C				
IP Rating	IP65				
Gross Weight/Carton	16.5KG	13KG	15KG	16KG	19KG
Product Size	230*65*400mm	240*65*530mm	250*65*645mm	255*70*760mm	255*70*850mm
Package Size	740*420*255mm 10Pcs/Box	550*375*265mm 5Pcs/Box	665*375*275mm 5Pcs/Box	770*305*275mm 4Pcs/Box	860*305*275mm 4Pcs/Box

**NELSON SOLAR**

BP 6635 Ouagadougou CNT Ouaga

BURUNDI **Free Trial**

WWW.NELSONSOLAR.COM



## Operational Approach:

1. Press the switch once. The lamp flashes once and works at motion sensor mode;
2. Press again. The lamp flashes twice and works at constant brightness mode;
3. Long pressing the switch to turn off the lamp.

## Lighting Data:

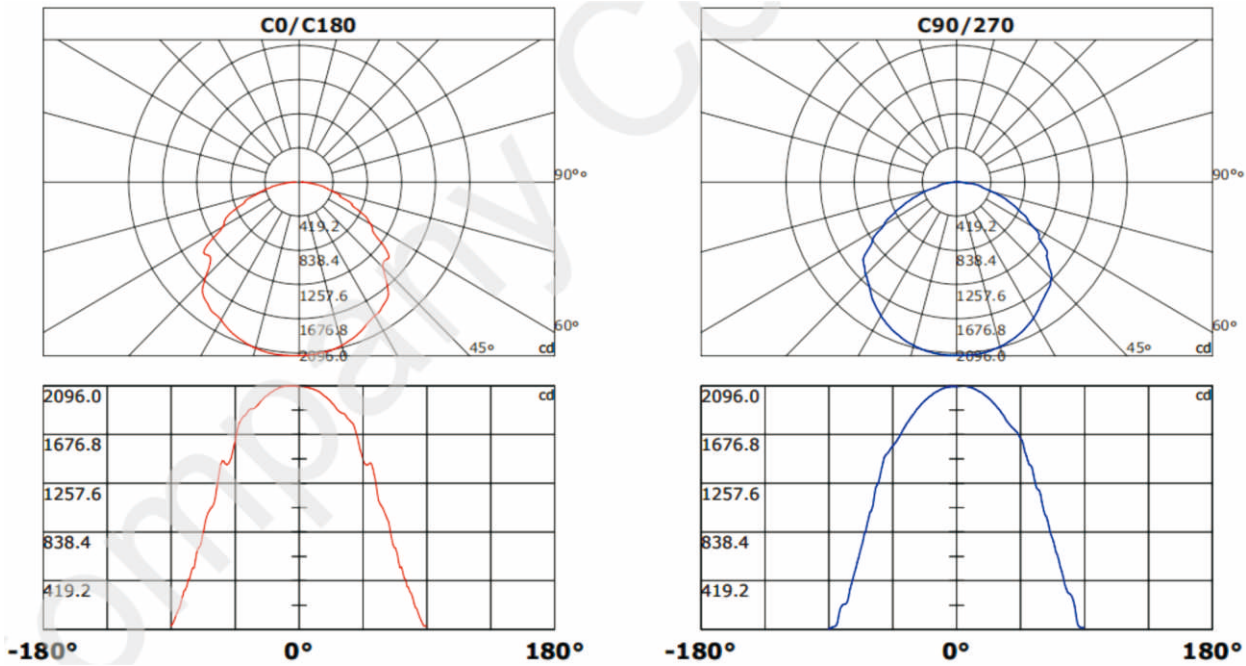

## Installation Dimension:

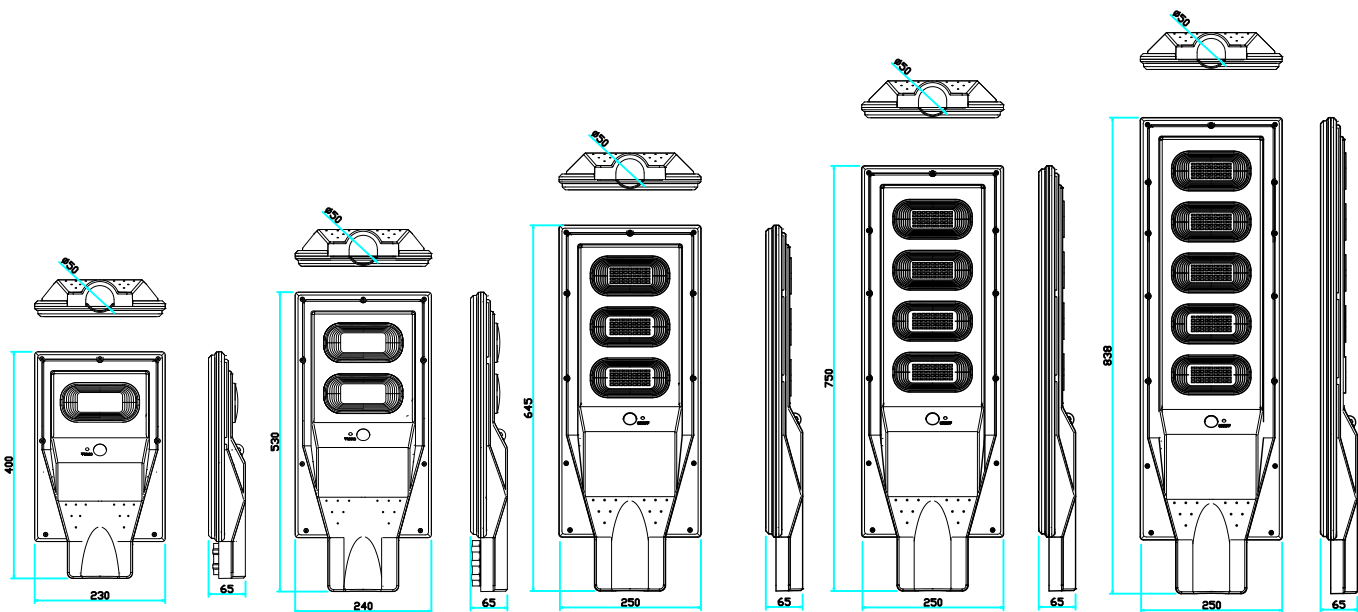

# Integration Solar Street Light

## Product Specification

80W/160W NELSON SOLAR



### Product Picture:



### Features:

- \* Aluminum lamp body
- \* No ac power cables, no electricity charges
- \* LED lumen 160lm/w
- \* IP65 rating

### Applications:

- \* Plazas, courtyards
- \* Factories, warehouses
- \* Gardens, parks
- \* Sporting venues

### Product Parameter:

Model	0917A80-01	0917B160-01
LED Type	160Pcs 3030LED	160Pcs 3030LED
Battery Type	LiFePO4 12.8V 30AH	LiFePO4 12.8V 60AH
Solar Panel Type	Polycrystalline 80W 18V	Polycrystalline 100W 18V
LED Lumen	160lm/w	
Color Temperature	3000K-6500K	
LED Lifespan	50000H	
Sensing Method	PIR Detection	
Operating Temperature	-20°C~60°C	
Storage Temperature	-30°C~70°C	
IP Rating	IP65	
Gross weight/Carton	18Kg	23Kg
Product Size	1085*378*280mm	1560*378*280mm
Package Size	1170*460*175mm 1Pcs/Box 420*220*255mm 2Pcs/Box	1635*460*175mm 1Pcs/Box 420*220*255mm 2Pcs/Box

Integration Solar Street Light

**NELSON SOLAR**

BP 6635 Ouagadougou CNT Ouaga

BURKINA FASO

WWW.NELSONSOLAR.COM



**Lighting Data:**

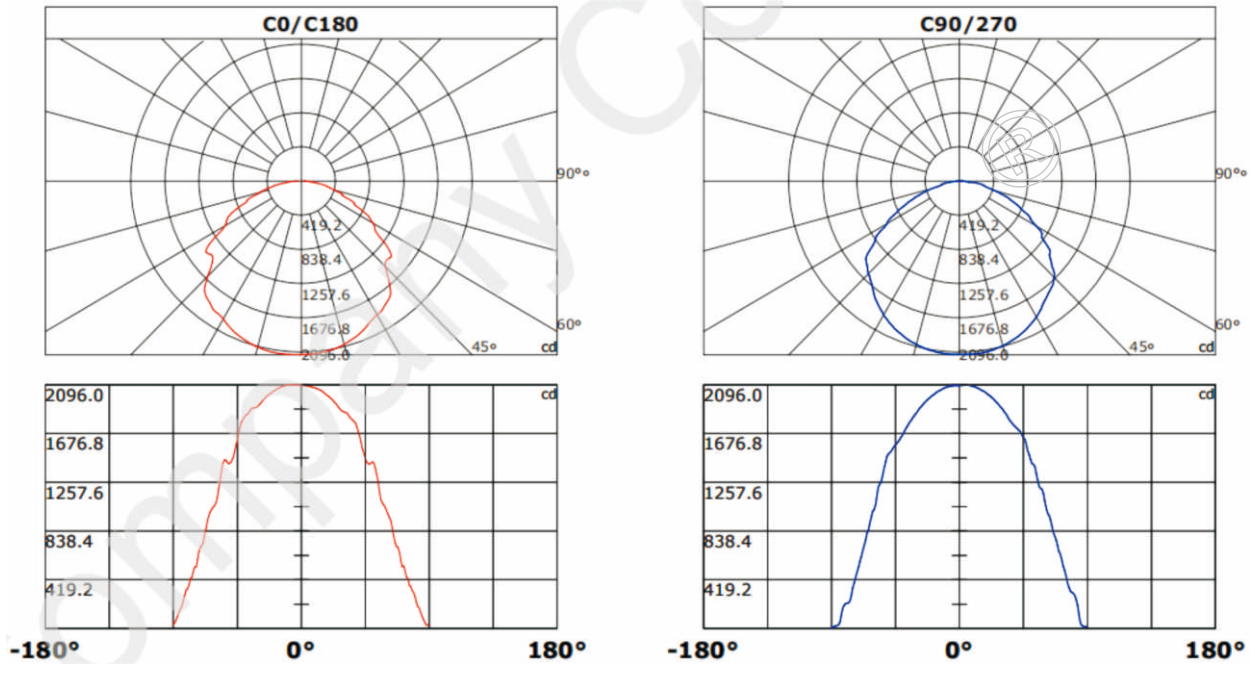

**Installation Dimension:**

